

Models 215V and 337

KUNKLE

Model 215V is Non-code Vacuum and Model 337 is ASME Section VIII, Air/Gas Vacuum, 'UV' National Board Certified, Safety Valves. PED Certified for Non-Hazardous Gas.

Features

- **Large nozzle design** provides high capacity.
- **Flat bronze valve seats are lapped** for optimum performance.
- **Warn ring offers easy adjustability** for precise opening with minimum pre-open or simmer and exact blowdown control.
- **Pivot between disc and spring** corrects misalignment and compensates for spring side thrust.

Model Descriptions

- **Model 337 has 'pull-ring' lift device** for easy manual testing.
- **Every valve is 100% tested/inspected** for pressure setting, blowdown and leakage.
- **All adjustments are factory sealed** to prevent tampering or disassembly.

Option

- SS trim. (nozzle and disc) (Variation 03)

Applications

- Protection of low to medium pressure high volume blowers, compressors and pneumatic conveying systems.
- Bulk hauling trailers/equipment.
- Light gauge tanks.
- Protection of high volume vacuum pumps and conveying systems.



Vacuum Limits

Model 215V:

2-inch HG
to 29-inch HG
[67.7 to 982 mbarg]
-20° to 406°F [-29° to 208°C]

Pressure and Temperature Limits

Model 337:

1 to 60 psig [0.07 to 4.1 barg]
-20° to 406°F [-29° to 208°C]



Advanced Industrial Design, Inc.
Powder and Bulk Materials Handling

Website: www.aid-inc.com
Contact Us At: info@aid-inc.com
Phone: (866) 439-6999

Kunkle Safety and Relief Products

Models 215V and 337

Capacities

Model 337, Non-code ¹ and ASME Section VIII Air (SCFM)			
Set Pressure (psig)	Valve Inlet and Outlet Size		
	2"	2 1/2"	3"
1	240	364	527
5	531	805	1166
10	741	1124	1628
15	948	1436	2081
20	1092	1656	2399
25	1237	1875	2718
30	1382	2095	3036
35	1542	2337	3386
40	1701	2578	3736
45	1860	2820	4086
50	2020	3061	4436
55	2179	3303	4786
60	2338	3544	5136

Note

1. No code stamp or 'NB' on nameplate below 15 psig set.

Model 337, Non-code ¹ and ASME Section VIII Air [Metric, Nm ³ /h]			
Set Pressure [barg]	Valve Inlet and Outlet Size		
	50 mm	63 mm	80 mm
0.5	1049	1589	2303
1.0	1457	2208	3200
1.5	1888	2861	4147
2.0	2235	3387	4910
2.5	2613	3959	5739
3.0	2995	4538	6579
3.5	3377	5117	7418
4.0	3760	5696	8258

Note

1. No code stamp or 'NB' on nameplate below 1.1 barg set.

Model 215V, Non-code Vacuum Air (SCFM)			
Relief Set (in, HG)	Valve Inlet and Outlet Size		
	2" Orifice Area, in ² 1.84	2 1/2" Orifice Area, in ² 2.79	3" Orifice Area, in ² 4.04
2	229	347	503
5	338	512	742
10	415	630	912
15	426	646	936
20	426	646	936
29	426	646	936

Model 215V, Non-code Vacuum Air [Metric, Nm ³ /h]			
Relief Set [mbarg]	Valve Inlet and Outlet Size		
	5.08 cm Orifice Area [11.86 cm ²]	6.35 cm Orifice Area [17.97 cm ²]	7.62 cm Orifice Area [26.05 cm ²]
50	328	498	722
100	450	682	988
150	533	807	1170
200	593	899	1303
250	638	966	1400
300	669	1014	1470
350	690	1046	1516
400	701	1062	1540
450	704	1067	1546
500	704	1067	1546
550	704	1067	1546
600	704	1067	1546
650	704	1067	1546
700	704	1067	1546
750	704	1067	1546



Advanced Industrial Design, Inc.
Powder and Bulk Materials Handling

Website: www.aid-inc.com
Contact Us At: info@aid-inc.com
Phone: (866) 439-6999

Models 215V and 337

Parts and Materials

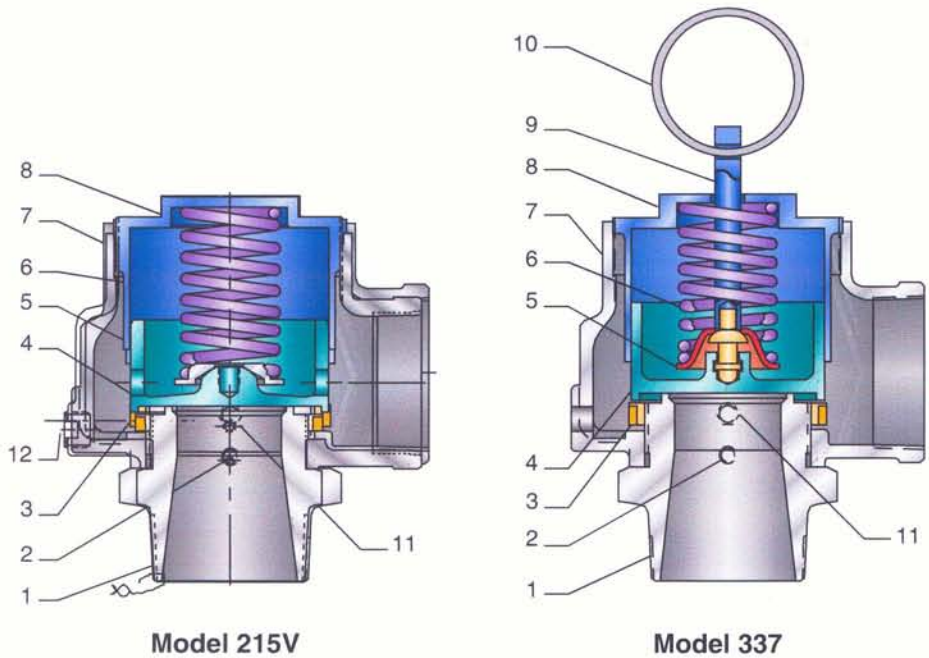

Models 215V and 337

No.	Part Name	215V	337
1	Nozzle ¹	Bronze, SB62	Bronze, SB62
2	Set Screw	Steel A108-1018 Brass Plated	Steel A108-1018 Brass Plated
3	Regulator Ring	Bronze B584 Alloy 84400	Bronze B584-C84400
4	Disc ¹	Bronze B584 Alloy 84400	Bronze B584-C84400
5	Spring Step	Steel A-109 Coated ³	Steel A109 Coated ³
6	Spring	SS, A313 TY 302	SS A313-302
7	Body	Cast Iron A-126, CL A or B	Iron A-126, CL A or B
8	Compression Screw	Bronze, B-584 Alloy 84400	Bronze, B584-C84400
9	Stem ²	N/A	Brass B16
10	Lift Ring ²	N/A	SS A313-302
11	Regulator Ring Set Screw	N/A	Brass B16
12	NPT Drainplug	Steel A108-1018	N/A

Notes

1. Disc and nozzle available in SSA-479 TY 316.
2. Stem and lift ring available on Model 337 only.
3. Corrosion preventative coating.

Specifications

Size Inlet and Outlet	Dimensions, in [mm]				Weight lb [kg]
	A	B	C 215V	C 337	
2" [50.8 mm]	3 1/4 [82.5]	3 [76.2]	6 1/2 [165.1]	7 [177.8]	8 [3.6]
2 1/2" [63.5 mm]	3 3/4 [95.2]	3 1/2 [88.9]	7 5/8 [194.6]	8 [203.2]	12 [5.4]
3" [76.2 mm]	4 1/4 [107.9]	4 [101.6]	8 1/2 [215.9]	9 [228.6]	20 [4.1]

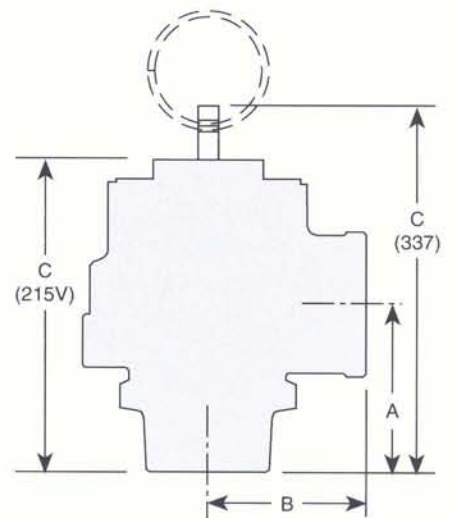

Model 337



Models 215V and 337

Model Number/Order Guide

